

CUMSA **NOW - DIEMAKER FRIENDLY...** MARKING UNITS FOR METAL STAMPINGS

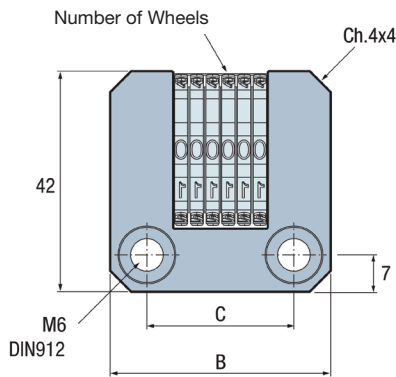

UM

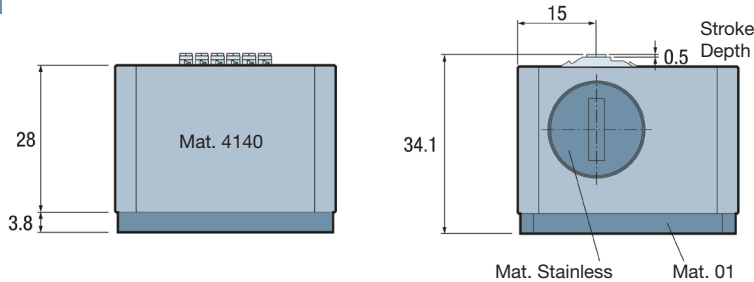

Part No.	Wheels	B	C
UM043642	4	36	22
UM064242	6	42	28

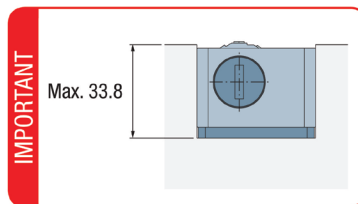

Patented System

Note: All dimensions are in mm

INTERCHANGEABLE MARKING WHEEL



Wheels are easy to replace and interchange for both 4 and 6 wheel units. Screwdriver tool needed.

RR

Part No.
RR180311

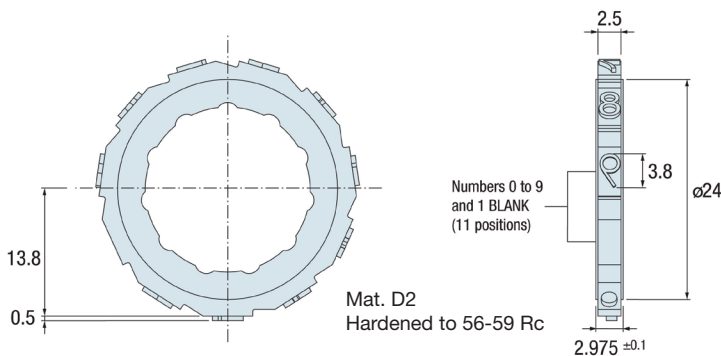

WHEN ORDERING PLEASE SPECIFY:

1. Part Number
2. Quantity

AVAILABLE FROM



superiordieset.com